

Automatic Dead weight tester - Hi-tech / Hydraulic

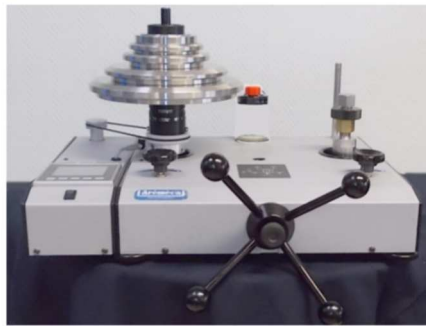

$$P = F/S$$

✓ **Applications**

This primary standard Range are designed to test, adjust and calibrate measuring instruments, mechanical or electronic pressure by comparison (pressure gauges, pressure transmitters or sensors or switches)

The dead weight tester consist of a pressure generator, a piston/cylinder unit, a set of weigh identified and of a computer on which is posted : the position of the piston and the value of pressure generated by the dead weight according to the various physical quantities.

The capstan is used to generate a pressure pushing the fluid through the piston. This pressure is balanced by the piston/cylinder assembly which allows to compare the instrument to be calibrated to the pressure values generated by the standard.

This reference instrument are used in factory or calibration laboratory. They are robust and easy to use and have a high long-term stability.

✓ **Technical specifications of the range BH4**

- **Calibration :** Our dead weight tester are calibrated under the following conditions of use :
Temperature 20°C - Pressure atmos. 1013.25 hPa - Humidity 50% - acceleration 9.80665 m/s²
In case you don't use it under the conditions mentioned above, it is necessary to recalculate the pressure generated by the dead weight according to the different variables.
- **Fluid :** Mineral or synthetic oil depending on model, colorless, compatible with medical or food uses – tank volume 125 cm³
- **Check/adjust the seat :** leveling bubble and adjustable feet
- **Connecting for the instrument to be tested :** swivel G1/2 standard – other optional fittings
- **Motorization :** motorized weight set drive by electric engine
- **Measure of the temperature :** Precision ± 0.1°C
- **Measure of the atmospheric pressure :** Precision ± 1HPa / range 0 to 1600 mbar / resolution = 1mbar
- **Calculator RS232 /mains 220v, 50Hz:**
 - with dynamic display of the position of the piston
 - with automatic display of the pressure generated by the dead weight according to the temperature, the atmospheric pressure
 - with a connection for the transfer of the data on computer, allowing a total traceability
- **Crankcase :** Light alloy aluminium AG3 + high-resistance paint
- **Capstan :** removable for transport
- **Piston/cylinder :** Single or twin piston tungsten carbide and/or treated steel depending the model –
Répeatability : 1.10⁻⁵ - **Sensitivity** : 3.10⁻⁵ - **Precision dead weight** : 5.10⁻⁵
- **Weight :** stainless steel – **Total weight** of the set of weights from 25 kg to 100 kg depending on model – Ergonomic shape of the masses, easy loading of the masses on the bell - **Marking** corresponding with the measuring unit choose (bar, mbar, KPa, PSI etc..) **Gravity** : standard (9.80665 m/s²) or local gravity without supplement
- **Operating temperature:** 18 to 28°C – 64 to 82°F

✓ **Technical product specifications**

- **Model :** BH4-300B sp - Dead weight tester single piston
 - **Measuring range :** 5 to 300 bar / 50 to 4000 PSI / 500 to 30000 kPa
 - **Accuracy :** 0.01% of reading up to 0.006% on request
 - **Weight dead weight without masses :** 24 kg
 - **Fluid :** Oil
 - **Material Piston/Cylinder :** P = tungsten carbide / C = treated steel
 - **Number of piston :** 1
- Unit supplied with : Operating instructions / AREMECA calibration certificate traceable to national standards / unit data sheet / 0.5 liter mineral oil / G1/2 outlet connector / tools / OP0002 suitcase for base

Note: All our documents can be delivered in English, French or German.

✓ **Standard device dimensions**

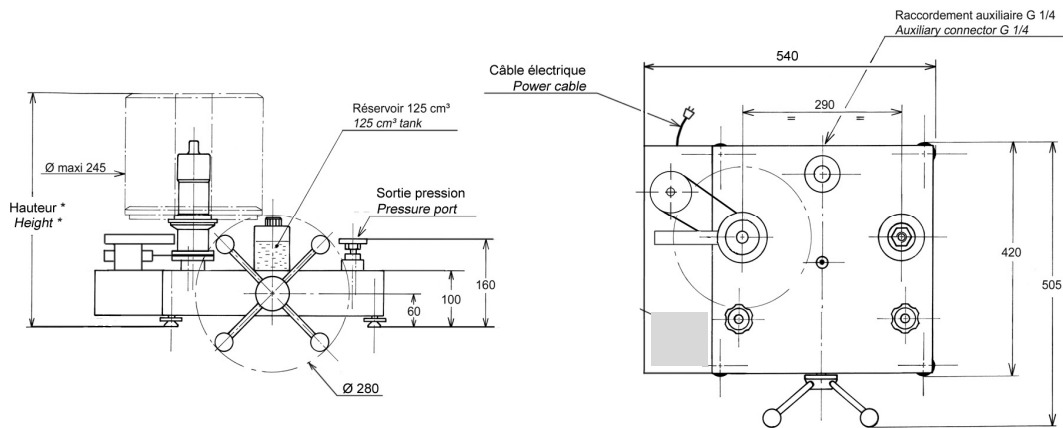

Height with standard set of weight : (bar, kPa) : 450 mm (PSI) : 465 mm Unit used : mm

CHOOSING OPTIONS

- Gravitation option OFFERED** : we will adjust your weight set to the standard or special G (give us the desired value).
- Unit option OFFERED** : choose the unit of the main weight set (e.g. PSI, BAR) delivered with the DWT
- Option OP237-200** : weights set adjustment from 1 mg to 50g with cofrac certificate

Standard set			
	Pressure (bar)	Total weight	Typical value (g)
Unit : BAR or kg/cm² (Ref. MB0020)	50	4	8000
	45	1	7200
	25	1	4000
	10	2	1600
	5	1	800
	2.5	1	400
	1	2	160
	0.5	1	80
Initial pressure bell	5	x	800
TOTAL	300	13	± 48 kg

Standard set			
	Pressure (PSI)	Total weight	Typical value (g)
Unit : PSI (Ref. MB0076)	500	6	5520
	450	1	4968
	250	1	2760
	100	2	1104
	50	1	552
	25	1	276
	10	2	110.4
	5	1	55.2
	2.5	1	27.5
	Initial pressure bell	50	x
TOTAL	4000	16	± 44 kg

Note : the calculator is able to transcribe the results of the weight set in bar, in the unit of your choice

- Optional DAKKS/DKD accredited calibration certificate.** Note: an AREMECA factory certificate is delivered with the dead weight tester. A DKD certificate will improve the results of your device
- Optional adaptation to corrosive products** : skydroll type, brake fluid etc...
- Maintenance option** : Our technical department is at your disposal to set up a maintenance contract for your device, as well as to schedule a calibration service - Calibration of the device is recommended every 2 to 5 years, depending on your use.

Carrying case option :

		<p>Ref OP0101 - Metal box for mass transport Dimensions : 260 x 260 x 310 mm - unloaded weight : 6 kg 7 weights max per box</p>
		<p>Ref OP0257 – carrying case for the masses</p>
		<p>Workstation layout : large: 355 x 505 x 310 mm - empty weight: 13 kg small: 290 x 250 x 310 mm - empty weight: 5 kg 1 or more boxes will be necessary depending on your DWT – Consult us !</p>
		<p><input checked="" type="checkbox"/> Ref OP0002 - Transport case for the balance or comparison bench. Included for range BH4 (BH5 or CH3 models contact us !)</p>

✓ **Accessories**



Ref OP0057 Accessories suitcase

Ref OP0023 Separator liquid/liquid

Ref OP0025 drain kit for oil

ref OP0037 Suitcase with 17 adaptors type M + G + NPT + BSP-TR / Pressure max 1200 bar

Ref OP0062 Cleaning bench

Ref OP0171 Suitcase adaptors type G / Ref OP0172 Suitcase adaptors type NPT / Ref OP0173 Suitcase adaptors type BSP-TR / Ref OP0174 Suitcase adaptors type M

✓ **Transport and packaging**

Designation/Reference	Dimension / carton or shipping crate	total weight (packaging + materiel)
Wooden over-wrapping DWT without options or accessories If option	79 x 48 x 34 cm 98 x 70 x 50 cm	(DWT + set of weights + cardboard packaging) Total weight ±96 kg Total weight to defined



- Note: Shipping is extra. Size may vary if accessories are purchased with the unit.

✓ **Other models available in the range BH4**

(Datasheet is available on request or on our website : www.aremeca-instrumentation.com)

Models single piston

Models	Accuracy	Measuring range	
		Bar ou kg/cm ²	PSI
BH4-7000B	0.05%	200 to 7000	2000 to 100000
BH4-6000B	0.05%	200 to 6000	2000 to 80000
BH4-5000B	0.02%	40 to 5000	600 to 72500
BH4-4000B	0.02%	40 to 4000	600 to 60000
BH4-3000B	0.02%	40 to 3000	600 to 44000
BH4-2500B	0.02%	40 to 2500	600 to 36200
BH4-2000B	0.02%	40 to 2000	600 to 30000
BH4-1200B sp	0.01%	2 to 1200	30 to 16000
BH4-700B sp	0.01%	2 to 700	30 to 10000
BH4-600B sp	0.01%	2 to 600	30 to 8000
BH4-400B sp	0.01%	2 to 400	15 to 5000
BH4-120B	0.01%	0.5 to 120	10 to 2000
BH4-60B	0.01%	0.2 to 60	3 to 800
BH4-30B	0.01%	0.1 to 30	2 to 400

Dual piston models : these dead weight tester integrating two pistons can get two ranges from a single set of weight

Models	Accuracy	Measuring range	
		Bar ou kg/cm ²	PSI
BH4-1200B dp	0.01%	1 to 60+ 20 to 1200	10 to 800 + 200 to 16000
BH4-700B dp	0.01%	1 to 60 + 10 to 700	10 to 800 + 100 to 10000
BH4-600B dp	0.01%	1 to 60 + 10 to 600	10 to 800 + 100 to 8000
BH4-400B dp	0.01%	1 to 60 + 5 to 400	10 to 800 + 50 to 5000
BH4-300B dp	0.01%	1 to 60 + 5 to 300	10 to 800 + 50 to 4000