



$P = F/S$

✓ **Applications**

This primary standard Range are designed to test, adjust and calibrate measuring instruments, mechanical or electronic pressure by comparison (pressure gauges, pressure transmitters or sensors or switches)

The dead weight tester consist of a pressure generator, a piston/cylinder unit, a set of weigh identified. The capstan is used to generate a pressure pushing the fluid through the piston. This pressure is balanced by the piston/cylinder assembly which allows to compare the instrument to be calibrated to the pressure values generated by the standard.

This reference instrument are used in factory or calibration laboratory. They are robust and easy to use and have a high long-term stability.

✓ **Technical specifics of the range BH2**

- **Calibration :** Our dead weight tester are calibrated under the following conditions of use :
Temperature 20°C - Pressure atmos. 1013.25 hPa - Humidity 50% - acceleration 9.80665 m/s²
In case you don't use it under the conditions mentioned above, it is necessary to recalculate the pressure generated by the dead weight according to the different variables.
- **Fluid :** Mineral or synthetic oil depending on model, colorless, compatible with medical or food uses – tank volume 125 cm³
- **Check/adjust the seat :** leveling bubble and adjustable feet
- **Connecting for the instrument to be tested :** swivel G1/2 standard – other optional fittings
- **Rotating weight :** Manual rotation of weights (or motorized if option OP0004 or OP0301)
- **Crankcase :** Light alloy aluminium AG3 + high-resistance paint
- **Capstan :** removable for transport
- **Piston/cylinder :** Single or twin piston tungsten carbide and/or treated steel depending the model –
Repeatability : 3.10⁻⁵ - **Sensitivity :** 1.10⁻⁵ - **Precision dead weight :** 10⁻⁴
- **Weight :** stainless steel – **Total weight** of the set of weights from 25 kg to 100 kg depending on model –
Ergonomic shape of the masses, easy loading of the masses on the bell - **Marking**
corresponding with the measuring unit choose (bar, mbar, KPa, PSI etc..)
Gravity : standard (9.80665 m/s²) or local gravity without supplement
- **Operating temperature:** 18 to 28°C – 64 to 82°F

✓ **Technical product specifications**

- **Model :** BH2-60B - dead weight single piston
- **Measuring range :** 0.2 to 60 bar / 3 to 800 PSI / 20 to 6000 kPa
- **Accuracy :** 0.01% of reading up to 0.006% on request
- **Weight of device without weight :** 22 kg / 24 kg if option OP0004 or OP0301
- **Fluid :** Oil
- **Material Piston/Cylinder :** P = tungsten carbide / C = treated steel
- **Number of piston :** 1

- Unit supplied with : Operating instructions / AREMECA calibration certificate traceable to national standards / unit data sheet / 0.5 liter mineral oil / G1/2 outlet connector / tools

Note: All our documents can be delivered in English, French or German.

✓ **Standard device dimensions**

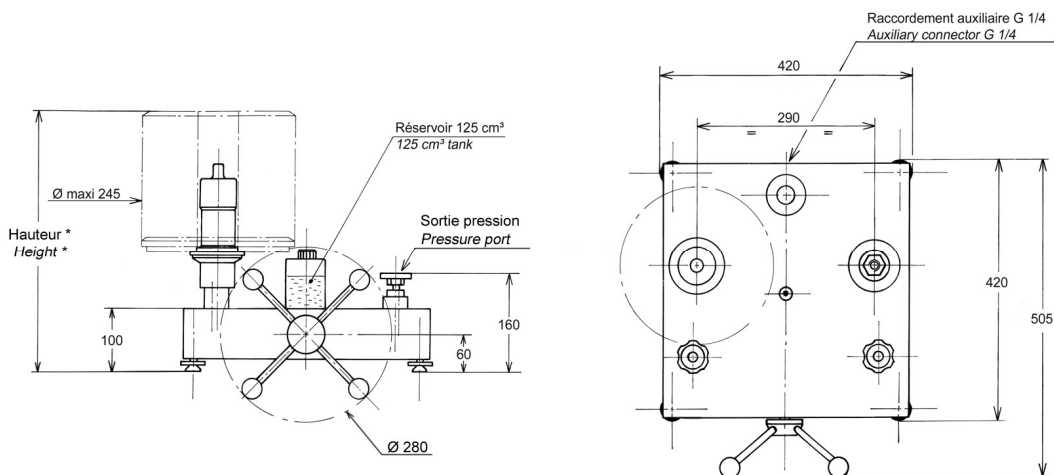

Height with standard set of weight : (bar) : 340 mm (PSI) : 350 mm

Unit used : mm

CHOOSING OPTIONS

- Gravitation option OFFERED** :: we will adjust your weight set to the standard or special G (give us the desired value).
- Unit option OFFERED** : choose the unit of the main weight set (e.g. PSI, BAR, Kg/cm²...) delivered with the DWT
- Intermediate weight set option** : the intermediate weight set is offered as an option, the unit will be the same as the one selected for the main weight set.

Standard set			
	Pressure (bar)	Total weight	Typical value (g)
Unit : BAR or kg/cm² (Ref. MB0024)	20	1	8000
	18	1	7200
	10	1	4000
	4	2	1600
	2	1	800
	1	1	400
	0.4	2	160
	0.2	1	80
	0.1	1	40
	Great initial pressure bell	2	x
Initial pressure	0.2	x	800
Small bell + weight adaptation			
TOTAL	62.3	11	±26 kg

Intermediate set in option			
	Pressure (bar)	Total weight	Typical value (g)
BAR or kg/cm² (Ref. MB0025)	0.04	2	16
	0.02	1	8
	0.01	1	4
	0.005	1	2
	TOTAL	0.115	5

Standard set			
	Pressure (PSI)	Total weight	Typical value (g)
Unit : PSI (Ref. MB0076)	200	2	5520
	180	1	4968
	100	1	2760
	40	2	1104
	20	1	552
	10	1	276
	4	2	110.4
	2	1	55.2
	1	1	27.6
	Great initial pressure bell	10	x
Initial pressure	3	x	83
Small bell + weight adaptation			
TOTAL	814	12	±23 kg

Intermediate set in option			
	Pressure (PSI)	Total weight	Typical value (g)
PSI (Ref. MB0029)	0.4	2	11
	0.2	1	5.5
	0.1	1	2.75
	0.05	1	1.25
	TOTAL	1.15	5

Other units are available on request

- Optional DAKS/DKD accredited calibration certificate.** Note: an AREMECA factory certificate is delivered with the dead weight tester. A DKD certificate will improve the results of your device
- Optional adaptation to corrosive products** : skydroll type, brake fluid etc...

Maintenance option : Our technical department is at your disposal to set up a maintenance contract for your device, as well as to schedule a calibration service - Calibration of the device is recommended every 2 to 5 years, depending on your use.

Option OP0004 : Motorization / LED display kit

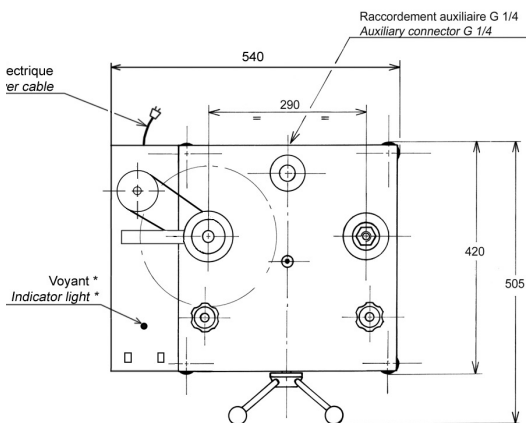

This option enhances the scale's functionality with :

- an automatic weight set motorization, which ensures regular rotation of the weights, avoids jolts on the piston, limits operator handling and improves scale stability during measurements
- a position sensor that displays the position of the piston. The operator can easily check that the balance is in equilibrium simply by checking the LED display, and no longer needs to check that the DWT is floating under the weight pan.

Option OP0301 : calculator + sensors + motorization / visualization

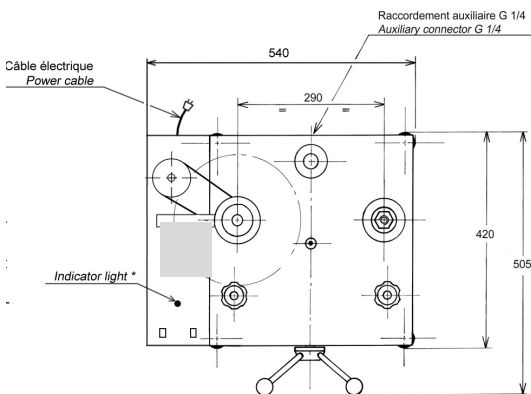

This option ensures traceability of your measurements and integrates numerous functions::

- automatic display of pressures generated by the DWT as a function of temperature and atmospheric pressure
- weight set motorization
- bargraph display of piston position
- unit conversion capability
- operator assistance in the measurement process
- data transfer to computer for full traceability and calibration certificate.

Carrying case option :

 	<p>Ref OP0101 - Metal box for mass transport Dimensions : 260 x 260 x 310 mm - unloaded weight : 6 kg 7 weights max per box</p>
 	<p>Ref OP0257 – carrying case for the masses</p>
 	<p>Workstation layout : large: 355 x 505 x 310 mm - empty weight: 13 kg small: 290 x 250 x 310 mm - empty weight: 5 kg</p> <p>1 or more boxes will be necessary depending on your DWT – Consult us !</p>
 	<p>Ref OP0002 - Transport case for the balance or comparison bench. (BH5 or CH3 models contact us !)</p>

✓ **Accessories**



Ref OP0057 Accessories suitcase

Ref OP0023 Separator liquid/liquid

Ref OP0025 drain kit for oil

ref OP0037 Suitcase with 17 adaptors type M + G + NPT + BSP-TR / Pressure max 1200 bar

Ref OP0062 Cleaning bench

Ref OP0171 Suitcase adaptors type G / Ref OP0172 Suitcase adaptors type NPT / Ref OP0173 Suitcase adaptors type BSP-TR / Ref OP0174 Suitcase adaptors type M

✓ **Transport and packaging**

Designation/Reference	Dimension / carton or shipping crate	total weight (packaging + materiel)
Wooden over-wrapping DWT without options or accessories If option	79 x 48 x 34 cm 98 x 70 x 50 cm	(DWT + set of weights + cardboard packaging) Total weight ±74 kg Total weight to be defined



- Note: Shipping is extra. Size may vary if accessories are purchased with the unit.

✓ **Other models available in the range BH2**

(Datasheet is available on request or on our website : www.aremeca-instrumentation.com)

Models single piston

Models	Accuracy	Measuring range		
		Bar ou kg/cm ²	PSI	kPa
BH2-7000B	0.05%	200 to 7000	2000 to 100000	20000 to 700000
BH2-6000B	0.05%	200 to 6000	2000 to 80000	20000 to 600000
BH2-5000B	0.02%	40 to 5000	600 to 72500	4000 to 500000
BH2-4000B	0.02%	40 to 4000	600 to 60000	4000 to 400000
BH2-3000B	0.02%	40 to 3000	600 to 44000	4000 to 300000
BH2-2500B	0.02%	40 to 2500	600 to 36200	4000 to 250000
BH2-2000B	0.02%	40 to 2000	600 to 30000	4000 to 200000
BH2-1200B sp	0.01%	2 to 1200	30 to 16000	200 to 120000
BH2-700B sp	0.01%	2 to 700	15 to 10000	200 to 70000
BH2-600B sp	0.01%	2 to 600	30 to 8000	200 to 60000
BH2-400B sp	0.01%	2 to 400	15 to 5000	200 to 40000
BH2-300B sp	0.01%	1 to 300	15 to 4000	100 to 30000
BH2-150B	0.01%	0.5 to 150	10 to 2000	50 to 15000
BH2-30B	0.01%	0.1 to 30	2 to 400	10 to 3000

Dual piston models : these dead weight tester integrating two pistons can get two ranges from a single set of weight

Models	Accuracy	Measuring range		
		Bar ou kg/cm ²	PSI	kPa
BH2-1200B dp	0.01%	1 to 60 + 20 to 1200	10 to 800 + 200 to 16000	100 to 6000 2000 to 120000
BH2-700B dp	0.01%	1 to 60 + 10 to 700	10 to 800 + 100 to 10000	100 to 6000 1000 to 70000
BH2-600B dp	0.01%	1 to 60 + 10 to 600	10 to 800 + 100 to 8000	100 to 6000 1000 to 60000
BH2-400B dp	0.01%	1 to 60 + 5 to 400	10 to 800 + 50 to 5000	100 to 6000 500 to 40000
BH2-300B dp	0.01%	1 to 60 + 5 to 300	10 to 800 + 50 to 4000	100 to 6000 500 to 30000