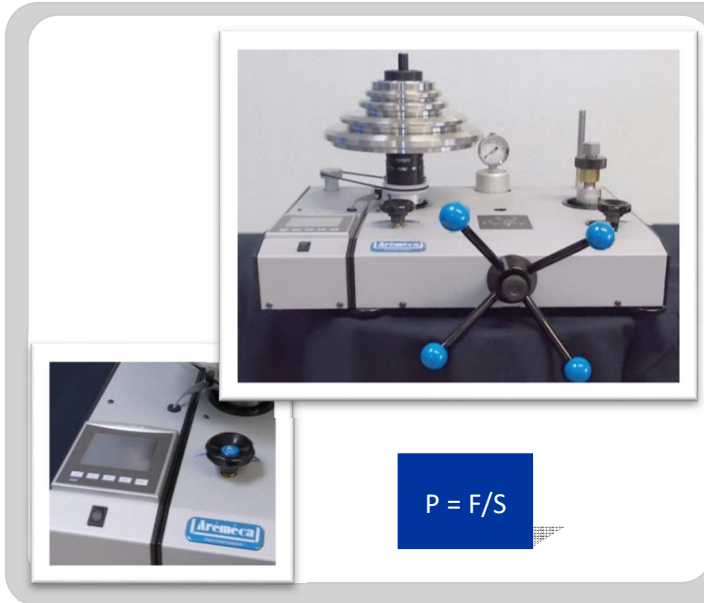

Automatic Dead weight tester - Hi-tech / Pneumatic✓ **Applications**

Range of Dead weight tester is designed to test, adjust and calibrate measuring instruments, mechanical or electronic pressure by comparison (pressure gauges, pressure transmitters or sensors or switches)

The dead weight tester are constituted by a pressure generator, a piston/cylinder unit, a set of weigh identified and of a computer on which is posted : the position of the piston and the value of pressure generated by the dead weight according to the various physical quantities.

The capstan allows to adjust the pressure by compressing the gas through the piston. This pressure is balanced by the set piston/cylinder what allows to compare the instrument to be calibrated in the values of pressures generated by the standard and indicated on the calculator. These dead weight are intended for the calibration in relative pressure. This reference instrument are used in factory or calibration laboratory. They are robust and easy to use and have a high long-term stability.

✓ **Technical specifications of the range BA4**

- **Calibration :** Our dead weight tester are calibrated under the following conditions of use :
Temperature 20°C - Pressure atmos. 1013.25 hPa - Humidity 50% - acceleration 9.80665 m/s²
In case you don't use it under the conditions mentioned above, it is necessary to recalculate the pressure generated by the dead weight according to the different variables²
- **Fluid :** The system of automatic lubrication integrated into the dead weight avoids the risks of contamination piston/cylinder. Colorless, compatible mineral oil with medical or food uses - volume of the tank 20 cm³
- **Source Pressure :** Dry air - gas connection ¼ cylindrical female
- **Check/adjust the seat :** leveling bubble and adjustable feet
- **Connecting for the instrument to be tested :** swivel G1/2 standard – other optional fittings
- **Motorization :** motorized weight set drive by electric engine
- **Measure of the temperature :** Precision ± 0.1°C
- **Measure of the atmospheric pressure :** Precision ± 1hPa
- **Calculator :**
 - with dynamic display of the position of the piston
 - with automatic display of the pressure generated by the dead weight according to the temperature, the atmospheric pressure
 - with a connection for the transfer of the data on computer, allowing a total traceability
- **Crankcase :** Light alloy aluminum AG3 + high-resistance paint
- **Capstan :** removable for transport
- **Piston/cylinder :** Single piston treated steel or stainless steel + hard chrome depending on the model -
Répeatability : 1.10⁻⁵ - **Sensitivity** : 0,5.10⁻⁵ - **Precision dead weight** : 5.10⁻⁵
- **Weight :** non magnetic stainless steel – **Total weight** of the set of weights from 33 kg to 48 kg depending on model –Ergonomic shape of the masses, easy loading of the masses on the bell -
Marking corresponding with the measuring unit choose (bar, mbar, KPa, PSI etc..) **Gravity** : standard (9.80665 m/s²) or local gravity without supplement
- **Operating temperature:** 18 to 28°C – 64 to 82°F

✓ **Technical product specifications**

- **Model :** BA4-200B - dead weight simple piston
 - **Measuring range :** 2.5 to 200 bar / 25 to 3000 PSI / 250 to 20000 kPa
 - **Accuracy :** 0.01% of reading up to 0.008% on request
 - **Weight of device without weight :** 24 kg
 - **Fluid :** This DWT needs to be connected to a pressure source.
 - **Material Piston/Cylinder :** P = tungsten carbide / C = treated steel
 - **Number of piston :** 1
- Unit supplied with : Operating instructions / AREMECA calibration certificate traceable to national standards / unit data sheet / 0.5 liter mineral oil / G1/2 outlet connector / tools / OP0002 suitcase for base
- Note: All our documents can be delivered in English, French or German.

✓ **Standard device dimensions**

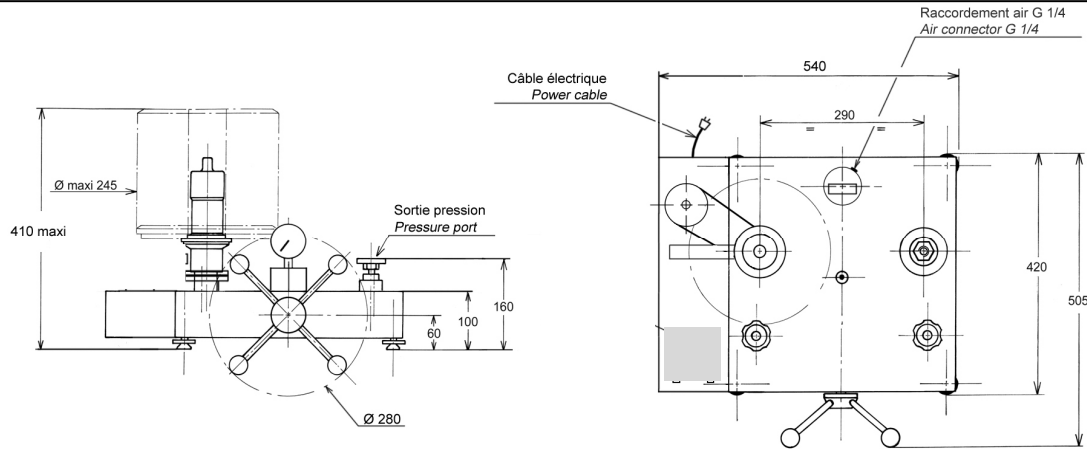

Height with standard set of weight : (bar, kPa) : 395 mm (PSI) : 379 mm

Unit used : mm

CHOOSING OPTIONS

- Gravitation option OFFERED** : we will adjust your weight set to the standard or special G (give us the desired value).
- Unit option OFFERED** : choose the unit of the main weight set (e.g. PSI, BAR) delivered with the DWT
- Option OP237-200** : weights set adjustment with cofrac certificate

Standard set			
	Pressure (bar)	Total weight	Typical value (g)
Unit : BAR or Kg/cm² (Ref. MB0031)	50	2	8000
	47.5	1	7600
	25	1	4000
	10	2	1600
	5	1	800
	2.5	1	400
	1	2	160
	0.5	1	80
Initial Pressure bell + weight adaptation	2.5		400
TOTAL	205	11	±33 kg

Standard set			
	Pressure (PSI)	Total weight	Typical value (g)
Unit : PSI	500	4	5520
	475	1	5244
	250	1	2760
	100	2	1104
	50	1	552
	25	1	276
	10	2	110.4
	5	1	55.2
	Initial Pressure bell	25	
TOTAL	3050	13	±34 kg

Optional :

- Set of weights adjustment from 1 mg to 50g with COFRAC certificat (Ref.OP237-200)

Note : the calculator is able to transcribe the results of the weight set in bar, in the unit of your choice

- Optional DAKS/DKD accredited calibration certificate.** Note: an AREMECA factory certificate is delivered with the dead weight tester. A DKD certificate will improve the results of your device

- Maintenance option** : Our technical department is at your disposal to set up a maintenance contract for your device, as well as to schedule a calibration service - Calibration of the device is recommended every 2 to 5 years, depending on your use.

Carrying case option :

		<p>Ref OP0101 - Metal box for mass transport Dimensions : 260 x 260 x 310 mm - unloaded weight : 6 kg 7 weights max per box</p>
		<p>Ref OP0257 – carrying case for the masses</p>
		<p>Workstation layout : large: 355 x 505 x 310 mm - empty weight: 13 kg small: 290 x 250 x 310 mm - empty weight: 5 kg 1 or more boxes will be necessary depending on your DWT – Consult us !</p>
		<p><input checked="" type="checkbox"/> Ref OP0002 - Transport case for the balance or comparison bench. Included for range BH4 (BH5 or CH3 models contact us !)</p>

✓ **Accessories**



Ref OP0057 Accessories suitcase

Ref OP0025 drain kit for oil

ref OP0037 Suitcase with 17 adaptors type M + G + NPT + BSP-TR / Pressure max 1200 bar

Ref OP0062 Cleaning bench

Ref OP0171 Suitcase adaptors type G / Ref OP0172 Suitcase adaptors type NPT / Ref OP0173 Suitcase adaptors type BSP-TR / Ref OP0174 Suitcase adaptors type M

✓ **Shipping and packaging**

- **Packaging** : woodpack is provided for the shipping

Designation/Reference	Dimension / carton or shipping crate	Weight empty / total weight (packaging + materiel)
Wooden over-wrapping DWT without options or accessories If option	79 x 48 x 34 cm 98 x 70 x 50 cm	(DWT + set of weights + cardboard packaging) Total weight ±80 kg Total weight to defined



- Note: Shipping is extra. Size may vary if accessories are purchased with the unit.

✓ **Other models available in the range BA4**

(Datasheet is available on request or on our website : www.aremeca-instrumentation.com)

Models simple piston

Models	Accuracy	Measuring range		
		Bar ou kg/cm ²	PSI	kPa
BA4-120B	0.01%	1 to 120	10 to 1600	100 to 12000
BA4-60B	0.01%	0.5 to 60	5 to 800	50 to 6000