



✓ **Applications**

Self compressor with a variable volume system, can work in air over the entire measuring vacuum (-0.9 bar) 20 bars without having to connect to a source of pressure. The position of the piston is visible through a slider

This device is ideal for maintenance operations and on-site verification, because it is integrated into a briefcase, lightweight and durable transport.

You can connect most measuring devices (pressure gauge, transmitter etc..) Through a system of interchangeable connection.

✓ **Technical specifications of the range CAA**

- Fluid :	clean and dry air type compressed air or azote
- Volume de fluid expelled :	340 cm <sup>3</sup>
- Connecting test :	Standard connector G1/2
- Connecting reference instrument :	Standard connector G1/2
- Can supply air :	connector G1/4 to connect to a pressure source useful for devices with high volume Death (beyond 200mm3) - indicator inlet pressure
- Carter :	light alloy aluminum AG3 + high resistance paint
- Position piston :	Visualization with an integrated cursor
- Capstan :	removable for transport
- Operating temperature:	18 to 28°C – 64 to 82°F

✓ **Technical product specifications**

- Model :	CAA - 20B
- Measuring range :	-0.9 à 20 bar / -13 à 290 PSI /
- Sensitivity :	10% Pmaxi = 0.0002 bar / 50% Pmaxi = 0.0005 bar / 100% Pmaxi = 0.001 bar
- Weight :	12 kg
- Typical cross-section of the piston :	low pressure = 31 cm <sup>2</sup>
- Number of piston :	1
- Material Piston/Cylinder :	P = carbide tungsten / C = treated steel
- Piping :	polyamide

- Unit supplied with : Operating instructions / unit data sheet / G1/2 outlet connector / tools

Note: All our documents are delivered in French + English

✓ **Dimensions of device**

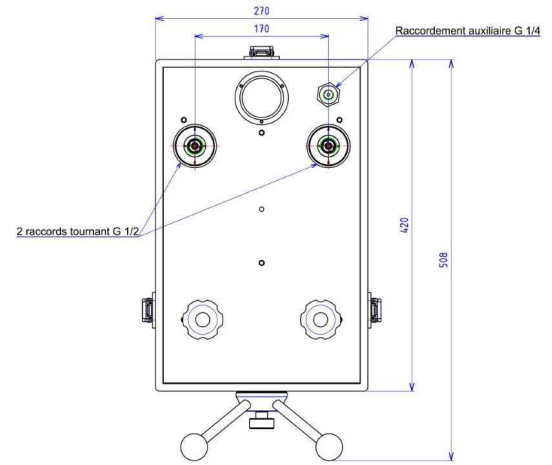
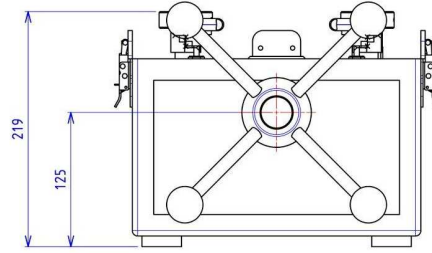
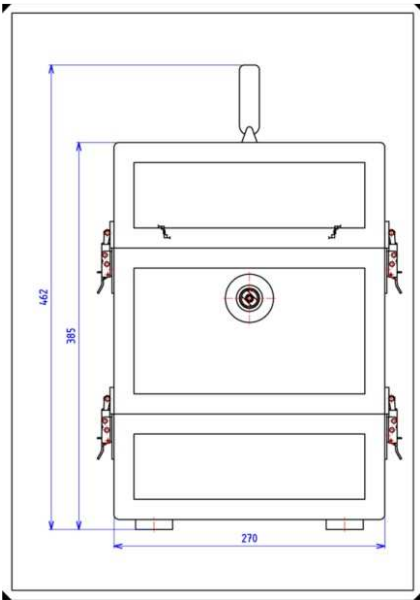

Unit used : mm

✓ **Options**

- Option: Oxygen degreasing (consult us)

✓ **Transport and packaging**

- **Packaging** : pack is provide for the shipping

Designation/Reference	Dimension / carton or shipping crate	Weight empty / total weight (packaging + device)
<b>packaging</b>	480 x 480 x 570 mm	total weight ±23 kg

- Note: Shipping is extra. Size may vary if accessories are purchased with the unit.

✓ **Other models available in the range CA**

(Datasheet is available on request)

Models	Measuring range		
	Bar or kg/cm <sup>2</sup>	PSI	kPa