



$$P = F/S$$

✓ Applications

This primary standard Range are designed to test, adjust and calibrate measuring instruments, mechanical or electronic pressure by comparison (pressure gauges, pressure transmitters or sensors or switches)

The dead weight tester consist of a pressure generator, a piston/cylinder unit, a set of weigh identified. The capstan is used to generate a pressure pushing the fluid through the piston. This pressure is balanced by the piston/cylinder assembly which allows to compare the instrument to be calibrated to the pressure values generated by the standard.

This reference instrument are used in factory or calibration laboratory. They are robust and easy to use and have a high long-term stability.

✓ Technical specifications of the range BH2

- **Calibration :** Our dead weight tester are calibrated under the following conditions of use :
Temperature 20°C - Pressure atmos. 1013.25 hPa - Humidity 50% - acceleration 9.80665 m/s²
In case you don't use it under the conditions mentioned above, it is necessary to recalculate the pressure generated by the dead weight according to the different variables.
- **Fluid :** Mineral or synthetic oil depending on model, colorless, compatible with medical or food uses – tank volume 125 cm³
- **Check/adjust the seat :** leveling bubble and adjustable feet
- **Connecting for the instrument to be tested :** swivel G1/2 standard – other optional fittings
- **Rotating weight :** Manual rotation of weights (or motorized if option OP0004 or OP0301)
- **Crankcase :** Light alloy aluminium AG3 + high-resistance paint
- **Capstan :** removable for transport
- **Piston/cylinder :** Single or twin piston tungsten carbide and/or treated steel depending the model –
Repeatability : 3.10⁻⁵ - **Sensitivity :** 1.10⁻⁵ - **Precision dead weight :** 10⁻⁴
- **Weight :** stainless steel – **Total weight** of the set of weights from 25 kg to 100 kg depending on model –
Ergonomic shape of the masses, easy loading of the masses on the bell - **Marking** corresponding with the measuring unit choose (bar, mbar, KPa, PSI etc..)
Gravity : standard (9.80665 m/s²) or local gravity without supplement
- **Operating temperature:** 18 to 28°C – 64 to 82°F

✓ Technical product specifications

- **Model :** BH2-400B dp – Dead weight tester double piston
- **Measuring range :** 1 to 400 bar
- **Uncertainty of the pressure measured by the DWT** Piston BP (1-60 bar) = 0.001 + 1x10⁻⁴ x P*/ Piston HP (60-400 bar) = 0.0015+1x10⁻⁴ x P* (*with P in bar)
- **Accuracy :** 0.01% of the scale, certificate Arémeca (if option COFRAC : 0.007%)
- **Weight dead weight without masses :** 22 kg / 24 kg if option OP0004 or OP0301
- **Base generator :** CH2-1250B
- **Fluid :** Oil H40 - fluid density : 860 kg/m³
- **Typical cross-section of the piston :** BP : 78.4472 mm² / HP : 15.6852 mm²
- **Material piston :** P:BP : stainless steel + P:HP : tungsten carbide / C = treated steel
- **Number of piston :** 2

- Unit supplied with : Operating instructions / AREMECA calibration certificate traceable to national standards / unit data sheet / 0.5 liter mineral oil / G1/2 outlet connector / tools

Note: All our documents are delivered in French + English

✓ **Standard device dimensions**

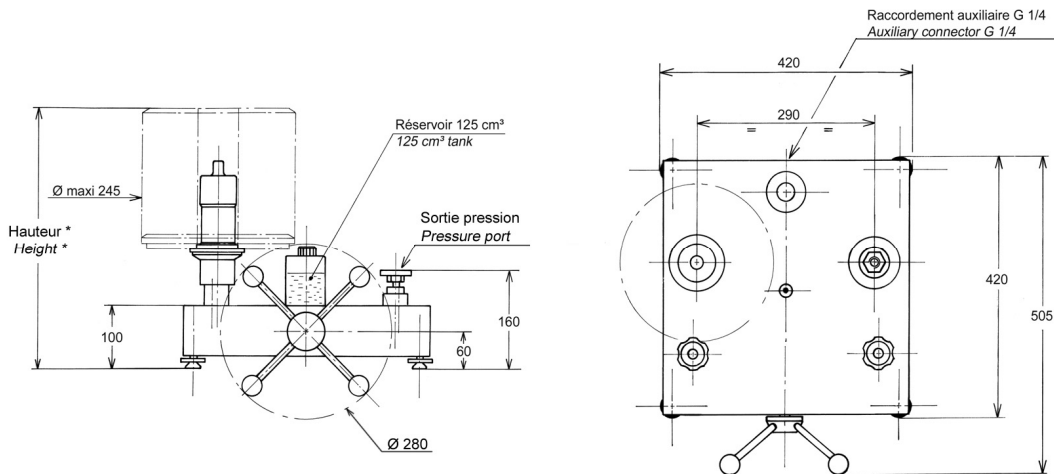

Height with standard set of weight : (bar) : 410 mm (PSI) : 420 mm

Unit used : mm

CHOOSING OPTIONS

Gravitation option OFFERED :: we will adjust your weight set to the standard or special G (give us the desired value).

Unit option OFFERED : choose the unit of the main weight set (e.g. PSI, BAR, Kg/cm²...) delivered with the DWT

Intermediate weight set option : the intermediate weight set is offered as an option, the unit will be the same as the one selected for the main weight set.

Standard set			
	Pressure (bar) BP/HP	Total weight	Typical value (g)
Unit : BAR or kg/cm² (Ref. MB0001)	10/50	6	8000
	9/45	1	7200
	5/25	1	4000
	2/10	2	1600
	1/5	1	800
	0.5/2.5	1	400
Initial pressure BP bell	1	x	800
Initial pressure HP bell + weight adaptation	5	x	800
TOTAL	85.5/303.5	12	±66 kg

Intermediate set in option			
	Pressure (bar) BP/HP	Total weight	Typical value (g)
BAR or kg/cm² (Ref. MB0002)	0.2/1	2	160
	0.1/0.5	1	80
	0.05/0.25	1	40
	0.02/0.1	2	16
	0.01/0.05	1	8
TOTAL	0.6/3	7	480 g

Standard set			
	Pressure (PSI) BP/HP	Total weight	Typical value (g)
Unit : PSI (Ref. MB0013)	100/500	6	5520
	90/450	1	4968
	50/250	1	2760
	20/100	2	1104
	10/50	1	552
	5/25	1	276
Initial pressure BP bell	10	x	552
Initial pressure HP bell + weight adaptation	50	x	552
TOTAL	855/4035	12	±45 kg

Intermediate set in option			
	Pressure (PSI) BP/HP	Total weight	Typical value (g)
PSI (Ref. MB0016)	2/10	2	110.4
	1/5	1	55.2
	0.5/2.5	1	27.6
	0.2/1	2	11
	0.1/0.5	1	5.5
TOTAL	6/30	7	331.1 g

Other units are available on request

Optional COFRAC or DAKKS/DKD accredited calibration certificate. Note: an AREMECA factory certificate is delivered with the DWT. A COFRAC certificate will improve the results of your device (performed at the national laboratory).

Optional adaptation to corrosive products : skydroll type, brake fluid etc...

Maintenance option : Our technical department is at your disposal to set up a maintenance contract for your device, as well as to schedule a calibration service - Calibration of the device is recommended every 2 to 5 years, depending on your use.

Option OP0004 : Motorization / LED display kit

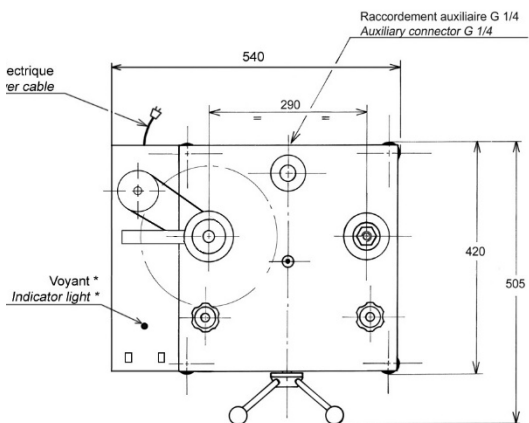

This option enhances the scale's functionality with :

- an automatic weight set motorization, which ensures regular rotation of the weights, avoids jolts on the piston, limits operator handling and improves scale stability during measurements
- a position sensor that displays the position of the piston. The operator can easily check that the balance is in equilibrium simply by checking the LED display, and no longer needs to check that the DWT is floating under the weight pan.



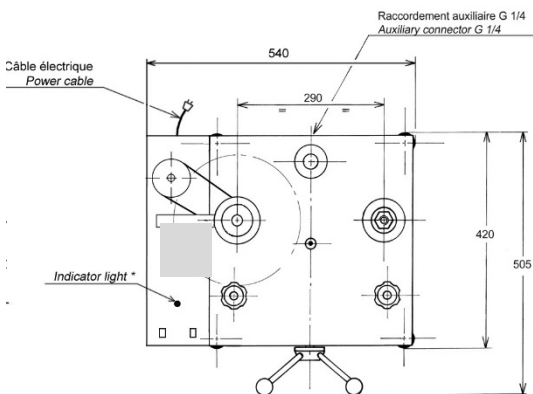

Option OP0301 : calculator + sensors + motorization / visualization



This option ensures traceability of your measurements and integrates numerous functions::

- automatic display of pressures generated by the DWT as a function of temperature and atmospheric pressure
- weight set motorization
- bargraph display of piston position
- unit conversion capability
- operator assistance in the measurement process
- data transfer to computer for full traceability and calibration certificate.

Carrying case option :

		<p>Ref OP0101 - Metal box for mass transport Dimensions : 260 x 260 x 310 mm - unloaded weight : 6 kg 7 weights max per box</p>
		<p>Ref OP0257 – carrying case for the masses</p>
		<p>Workstation layout : large: 355 x 505 x 310 mm - empty weight: 13 kg small: 290 x 250 x 310 mm - empty weight: 5 kg 1 or more boxes will be necessary depending on your DWT – Consult us !</p>
		<p>Ref OP0002 - Transport case for the balance or comparison bench. (BH5 or CH3 models contact us !)</p>

✓ **Accessories**



Ref OP0057 Accessories suitcase

Ref OP0023 Separator liquid/liquid

Ref OP0025 drain kit for oil

ref OP0037 Suitcase with 17 adaptors type M + G + NPT + BSP-TR / Pressure max 1200 bar

Ref OP0062 Cleaning bench

Ref OP0171 Suitcase adaptors type G / Ref OP0172 Suitcase adaptors type NPT / Ref OP0173 Suitcase adaptors type BSP-TR / Ref OP0174 Suitcase adaptors type M

✓ **Transport and packaging**

Designation/Reference	Dimension / carton or shipping crate	total weight (packaging + materiel)
Wooden over-wrapping DWT without options or accessories If option OP0004 or OP0301 ->	79 x 48 x 34 cm 98 x 70 x 50 cm	(DWT + set of weights + cardboard packaging) Total weight ±97 kg Total weight ±104 kg



- Note: Shipping is extra. Size may vary if accessories are purchased with the unit.

✓ **Other models available in the range BH2**

(Datasheet is available on request or on our website : www.aremeca-instrumentation.com)

Models single piston

Models	Accuracy	Measuring range		
		Bar or kg/cm ²	PSI	kPa
BH2-5000B	10 ⁻⁴	40 to 5000	600 to 72500	4000 to 500000
BH2-4000B	10 ⁻⁴	40 to 4000	600 to 60000	4000 to 400000
BH2-3000B	10 ⁻⁴	40 to 3000	600 to 44000	4000 to 300000
BH2-2500B	10 ⁻⁴	40 to 2500	600 to 36200	4000 to 250000
BH2-2000B	10 ⁻⁴	40 to 2000	600 to 30000	4000 to 200000
BH2-1200B sp	10 ⁻⁴	2 to 1200	30 to 16000	200 to 120000
BH2-600B sp	10 ⁻⁴	2 to 600	30 to 10000	200 to 60000
BH2-300B sp	10 ⁻⁴	1 to 300	15 to 4000	100 to 30000
BH2-150B	10 ⁻⁴	0.5 to 150	10 to 2000	50 to 15000
BH2-60B	10 ⁻⁴	0.2 to 60	3 to 800	20 to 6000
BH2-30B	10 ⁻⁴	0.1 to 30	2 to 400	10 to 3000

Models double piston : this dead weight tester including two piston can get two ranges from a single set of weight

Models	Accuracy	Measuring range		
		Bar or kg/cm ²	PSI	kPa
BH2-1200B dp	10 ⁻⁴	1 to 60 + 20 to 1200	10 to 800 + 200 to 16000	100 to 6000 2000 to 120000
BH2-600B dp	10 ⁻⁴	1 to 60 + 10 to 600	10 to 800 + 100 to 8000	100 to 6000 1000 to 60000

You'll find other devices and accessories on our website: www.aremeca-instrumentation.com