



✓ **Applications**

The range of compressors is designed to test, adjust and calibrate measuring instruments mechanical or electronic pressure by comparison (pressure gauges, pressure transmitters or sensors or switches).

These generators are equipped with a pressure tank visible level, two valves connected by a set of two-stage variable volumes. The capstan can generate the pressure pushing the fluid through the variable volumes to fittings provided for receiving the pressure instruments. These compressors are designed for industry or laboratory. They are robust and easy to use and have a very high long-term stability.

They have the opportunity to grow in dead weight tester by simply adding a kit with : a set piezometric and a set of weights.

✓ **Technical specifications of the range CO**

- **Control/tests :** Our bench pressure are controled under the following conditions of use :  
Temperature 20°C - Pressure atmos. 1013.25 hPa - Humidity 50% - acceleration 9.80665 m/s<sup>2</sup>)
- **Fluid :** water
- **Tank :** 125 cm<sup>3</sup>
- **Maximum volume of fluid expelled :** 61 cm<sup>3</sup>
- **Check/adjust the seat :** leveling bubble and adjustable feet
- **Connection for the instrument to be tested :** swivel G1/2 standard – other optional fittings
- **Carter :** Light alloy aluminium AG3 + high-resistance paint
- **Capstan :** Removable for transport
- **Operating temperature:** 18 to 28°C – 64 to 82°F

✓ **Technical product specifications**

- **Model :** CO-1000B
- **Measuring range :** 0 to 1000 bar / 0 to 14500 PSI / 0 to 100000 kPa
- **Sensitivity :** 10% Pmaxi = 0.01 bar / 50% Pmaxi = 0.1 bar / 100% Pmaxi = 0.2 bar
- **Reference :** pressure gauge is delivered an option
- **Weight comparator :** 18 kg
- **Section of pistons :** low pressure = 7.1 cm<sup>2</sup> / High pressure = 0.8cm<sup>2</sup>
- **Number of piston :** 2
- **Material Piston/Cylinder :** P:BP = stainless steel + HP = treated steel / C = stainless steel
- **Piping :** stainless steel

- Unit supplied with : Operating instructions / unit data sheet / G1/2 outlet connector / tools

Note: All our documents are delivered in French + English

✓ **Standard device dimensions**

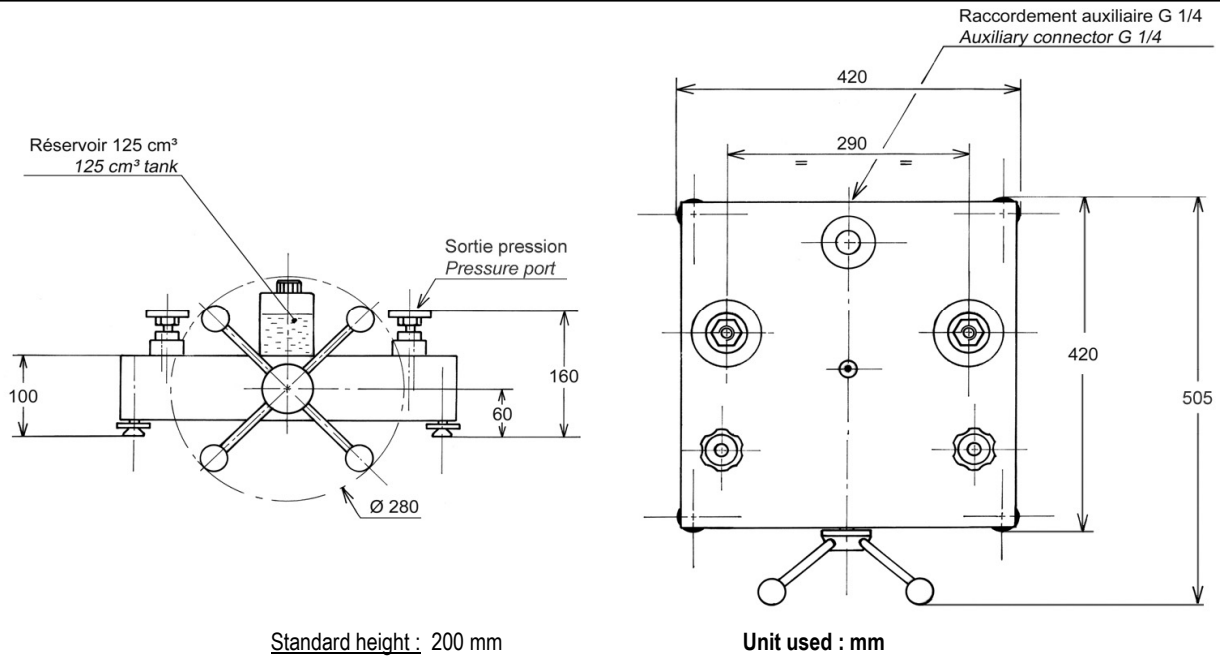

Standard height : 200 mm

✓ **Options of the generator**

- Ref OP0158 : reservoir pump 327cm<sup>2</sup>

✓ **Accessories**



Ref OP0057 accessories tools

Ref OP0023 Separator all fluids up to 800

Ref OP0025 Kit drain tank

ref OP0037 - suitcase with 17 connectors M + G + NPT + BSP-TR

Ref OP0171 suitcase connectors G / Ref OP0172 suitcase connectors NPT / Ref OP0173 suitcase connectors BSP-TR / Ref OP0174 suitcase connectors M

Ref OP0062 Bench cleaning

Ref OP0303 Control bloc for pressure gauges

✓ **Suitcase for transport**

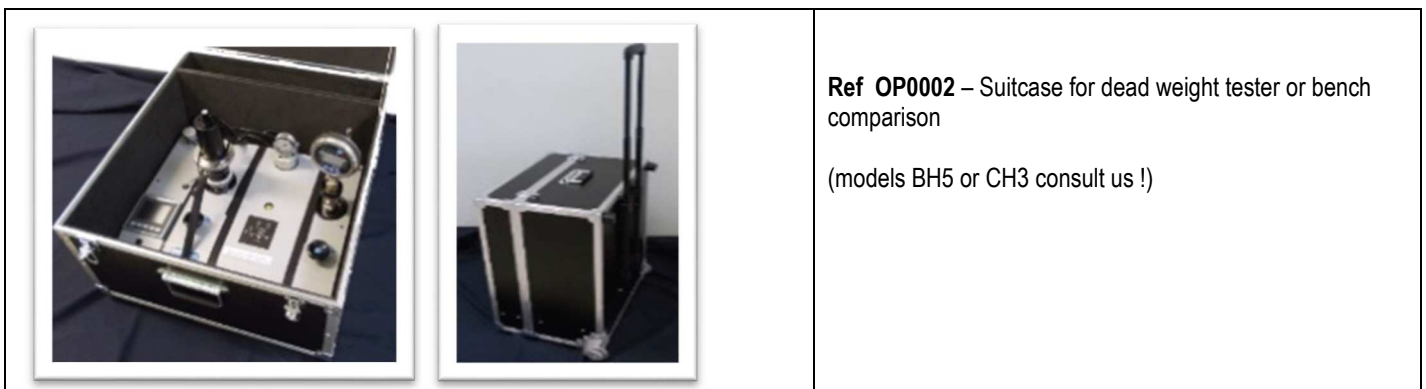

**Ref OP0002** – Suitcase for dead weight tester or bench comparison

(models BH5 or CH3 consult us !)

✓ **Transport and packaging**

- **Packaging** : pack is provide for the shipping

Designation/Reference	Dimension / carton or shipping crate	Weight empty / total weight (packaging + device)
<b>packaging</b>	480 x 480 x 340 mm	Total weight $\pm$ 30 kg



- Note: Shipping is extra. Size may vary if accessories are purchased with the unit.

✓ **Other models available in the range CO**

*(Datasheet is available on request or on our website : [www.aremeca-instrumentation.com](http://www.aremeca-instrumentation.com))*

Models	Measuring range		
	Bar or kg/cm <sup>2</sup>	PSI	kPa
CO-800	0 to 800	0 to 11600	0 to 80000