

$$P = F/S$$

✓ **Applications**

Range of Dead weight tester is designed to test, adjust and calibrate measuring instruments, mechanical or electronic pressure by comparison (pressure gauges, pressure transmitters or sensors or switches)

The dead weight tester are constituted by a pressure generator, a piston/cylinder unit, a set of weigh identified and of a computer on which is posted : the position of the piston and the value of pressure generated by the dead weight according to the various physical quantities.

The capstan allows to adjust the pressure by compressing the gas through the piston. This pressure is balanced by the set piston/cylinder what allows to compare the instrument to be calibrated in the values of pressures generated by the standard and indicated on the calculator. These dead weight are intended for the calibration in relative pressure. This reference instrument are used in factory or calibration laboratory. They are robust and easy to use and have a high long-term stability.

✓ **Technical specifications of the range BA4**

- **Calibration :** Our dead weight tester are calibrated under the following conditions of use :  
Temperature 20°C - Pressure atmos. 1013.25 hPa - Humidity 50% - acceleration 9.80665 m/s<sup>2</sup>  
In case you don't use it under the conditions mentioned above, it is necessary to recalculate the pressure generated by the dead weight according to the different variables<sup>2</sup>
- **Fluid :** The system of automatic lubrication integrated into the dead weight avoids the risks of contamination piston/cylinder. Colorless, compatible mineral oil with medical or food uses - volume of the tank 20 cm<sup>3</sup>
- **Source Pressure :** Dry air - gas connection ¼ cylindrical female
- **Check/adjust the seat :** leveling bubble and adjustable feet
- **Connecting for the instrument to be tested :** swivel G1/2 standard – other optional fittings
- **Motorization :** training the weight in rotation by electric engine
- **Measure of the temperature :** Precision ± 0.1°C
- **Measure of the atmospheric pressure :** Precision ± 1hPa
- **Measure of the hygrometry :** Precision ± 10%
- **Calculator :**
  - with dynamic display of the position of the piston
  - with automatic display of the pressure generated by the dead weight according to the temperature, the atmospheric pressure and the hygrometry
  - with a connection for the transfer of the data on computer, allowing a total traceability
- **Crankcase :** Light alloy aluminum AG3 + high-resistance paint
- **Capstan :** removable for transport
- **Piston/cylinder :** Single piston treated steel or stainless steel + hard chrome depending on the model -  
**Répeatability** : 1.10<sup>-5</sup> - **Sensitivity** : 0,5.10<sup>-5</sup> - **Precision dead weight** : 5.10<sup>-5</sup>
- **Weight :** non magnetic stainless steel – **Total weight** of the set of weights from 33 kg to 48 kg depending on model –Ergonomic shape of the masses, easy loading of the masses on the bell -  
**Marking** corresponding with the measuring unit choose (bar, mbar, KPa, PSI etc..) -  
**Gravity** : standard (9.80665 m/s<sup>2</sup>) or local gravity without supplement
- **Operating temperature:** 18 to 28°C – 64 to 82°F

✓ **Technical product specifications**

- Model :	BA4-200B - dead weight simple piston
- Measuring range :	2.5 to 200 bar / 25 to 3000 PSI / 250 to 20000 kPa
- Uncertainty of the pressure measured by the DWT :	0.001 + ( 0.5.10 <sup>-4</sup> x P) (with P en bar)
- Accuracy :	0.005% of the scale certificate aremeca (option COFRAC)
- Weight dead weight without weight :	24 kg
- Base generator :	CA2-200B
- Fluid :	This DWT needs to be connected to a pressure source.
- Typical cross-section of the piston :	15.6966 mm <sup>2</sup>
- Material Piston/Cylinder :	P = tungsten carbide / C = treated steel
- Number of piston :	1

✓ **Various**

- **Device delivered with :** a user manual / an AREMECA calibration certificate traceable to national standards / a technical sheet of the device / 0.5 liter of mineral oil if lubrication system / G1/2 outlet fitting / tools

Note: All our documents are issued in French + English

- **Maintenance :** Our technical service department is at your disposition for the revision, calibration or service your unit – Calibration device recommended every 2 or 5 years depending on your use

✓ **Dimensions of device**

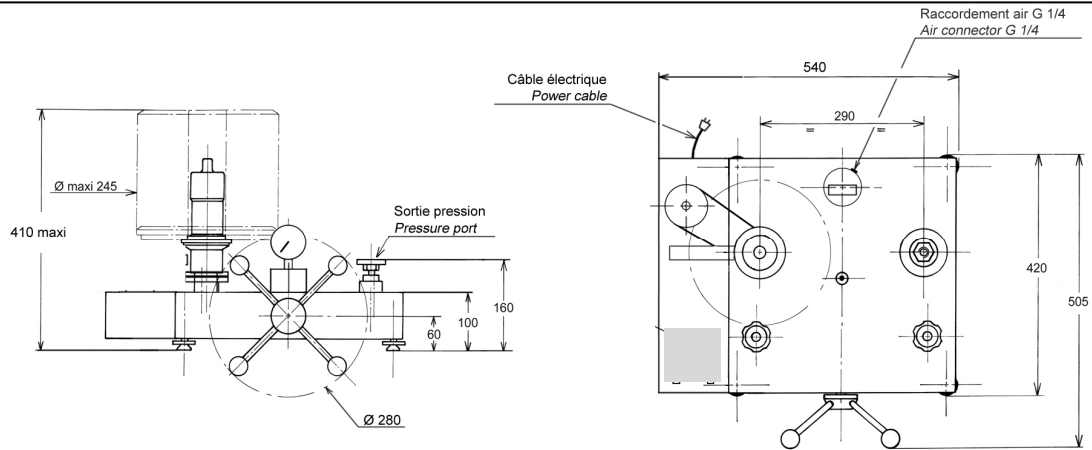

Height with standard set of weight : (bar, kPa) : 395 mm (PSI) : 379 mm

Unit used : mm

✓ **Standard weight sets**

Standard set			
	Pressure (bar)	Total weight	Typical value (g)
<b>Unit : BAR or Kg/cm<sup>2</sup></b> (Ref. MB0031)	50	2	8000
	47.5	1	7600
	25	1	4000
	10	2	1600
	5	1	800
	2.5	1	400
	1	2	160
	0.5	1	80
Initial Pressure bell + weight adaptation	2.5		400
<b>TOTAL</b>	<b>205</b>	<b>11</b>	<b>±33 kg</b>

Optional :

- Set of weights adjustment from 1 mg to 50g with COFRAC certificat (Ref.OP237-200)

Standard set			
	Pressure (PSI)	Total weight	Typical value (g)
<b>Unit : PSI</b>	500	4	5520
	475	1	5244
	250	1	2760
	100	2	1104
	50	1	552
	25	1	276
	10	2	110.4
	5	1	55.2
	Initial Pressure bell	25	
<b>TOTAL</b>	<b>3050</b>	<b>13</b>	<b>±34 kg</b>

Note : the calculator is able to transcribe the results of the weight set in bar, in the unit of your choice

✓ **Options of the dead weight tester**

- **FREE gravitation option** : we will adjust your weight set to the standard or special G (give us the desired value)
- Certificate option : DKD/DAkks or COFRAC accredited calibration certificate

✓ **Suitcase for shipping**

	<p>Ref OP0101 - Metal box for mass transport Dimensions : 260 x 260 x 310 mm - unloaded weight : 6 kg 7 weights max per box</p>
	<p>Ref OP0301 – carrying case for the masses</p>
	<p>Workstation layout : large: 355 x 505 x 310 mm - empty weight: 13 kg small: 290 x 250 x 310 mm - empty weight: 5 kg  1 or more boxes will be necessary depending on your DWT – Consult us !</p>
	<p>Ref OP0002 - Transport case for the balance or comparison bench. (BH5 or CH3 models contact us !)</p>

✓ **Accessories**



Ref OP0057 Accessories suitcase

Ref OP0025 drain kit for oil

ref OP0037 Suitcase with 17 adaptors type M + G + NPT + BSP-TR / Pressure max 1200 bar

Ref OP0062 Cleaning bench

Ref OP0171 Suitcase adaptors type G / Ref OP0172 Suitcase adaptors type NPT / Ref OP0173 Suitcase adaptors type BSP-TR / Ref OP0174 Suitcase adaptors type M

You will find other accessories on our website: [www.aremeca-instrumentation.com](http://www.aremeca-instrumentation.com)

✓ **Shipping and packaging**

- **Packaging** : woodpack is provided for the shipping

Designation/Reference	Dimension / carton or shipping crate	Weight empty / total weight (packaging + materiel)
<b>Dead weight without weight</b>	470 x 470 x 240 mm	Carton empty 1.5 kg Total weight ±24 kg
<b>Standard weight set</b>	300 x 300 x 170 mm	Carton empty 1.5 kg Total weight ± 35 kg
<b>Wood packaging</b> SB0003	980 x 700 x 500 mm	Suitcase empty 20 kg Total weight ± 79 kg (dead weight + weight set + packaging)



SB0003

- **Note** : shipping is extra.

✓ **Other models available in the range BA4**

(Datasheet is available on request or on our website : [www.aremeca-instrumentation.com](http://www.aremeca-instrumentation.com))

Models simple piston

Models	Accuracy	Measuring range		
		Bar ou kg/cm <sup>2</sup>	PSI	kPa
BA4-120B	10 <sup>-4</sup>	1 to 120	10 to 1600	100 to 12000
BA4-60B	10 <sup>-4</sup>	0.5 to 60	5 to 800	50 to 6000