



✓ **Applications**

The range of compressors is designed to test, adjust and calibrate measuring instruments mechanical or electronic pressure compared to a standard

They consist of a pool of oil sight gauge connected to a piston / cylinder unit. The capstan can generate a pressure by compressing the fluid through the piston. Two connectors are provided for receiving the instruments compared.

These compressors are designed to pressure the relative calibration. They are robust and easy to use and have the opportunity to grow in dead weight tester by simply adding a kit comprising: piezometric and a set of weights.

✓ **Technical specifications of the range CA2**

- Fluid : clean, dry air type compressed air or azote
- Volume de fluid expelled : 15 cm³
- Check/adjust the seat : leveling bubble and adjustable feet
- Connection for the instrument to be tested : swivel G1/2 standard – other optional fittings
- Carter : Light alloy aluminium AG3 + high-resistance paint
- Capstan : Removable for transport
- Operating temperature: 18 to 28°C – 64 to 82°F

✓ **Technical product specifications**

- Model : CA2-200B
- Measuring range : 0 to 200 bar / 0 to 3000 PSI / 0 to 20000 kPa
- Sensitivity : 10% Pmaxi = 0.001 bar / 50% Pmaxi = 0.002 bar / 100% Pmaxi = 0.005 bar
- Weight comparator : 18 kg
- Section of the piston : low pressure = 1.8 cm²
- Number of piston : 1
- Material Piston/Cylinder : P:BP = aluminum + HP= stainless steel / C = aluminium
- Piping : copper

- Unit supplied with : Operating instructions / unit data sheet / G1/2 outlet connector / tools

Note: All our documents are delivered in French + English

✓ **Dimensions of device**

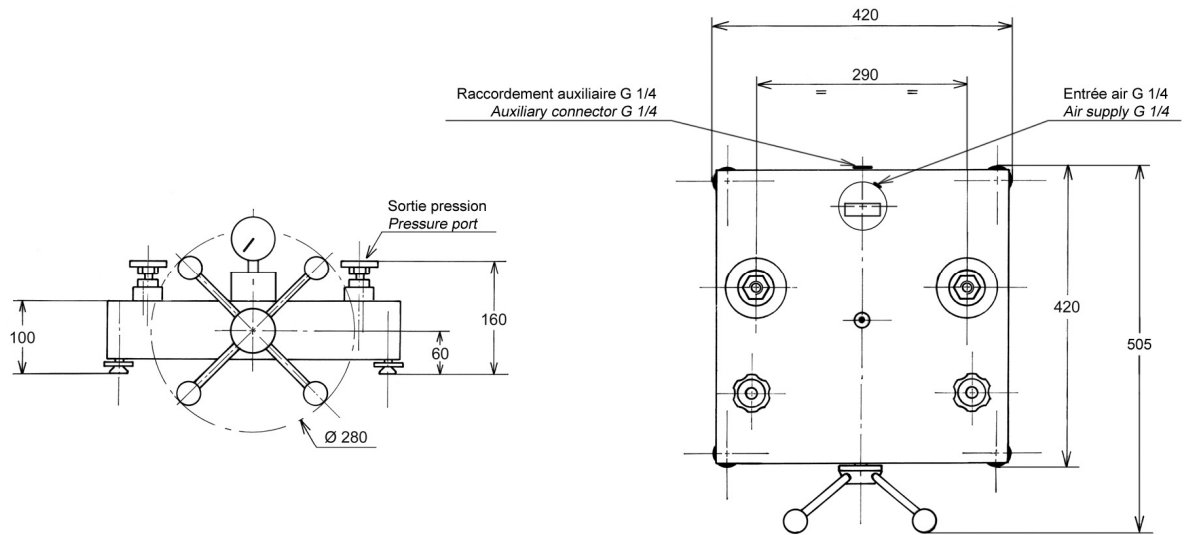



Unit used : mm

✓ **Options of the generator**

- Option: Oxygen degreasing (consult us)

✓ **Transformation into a DWT**

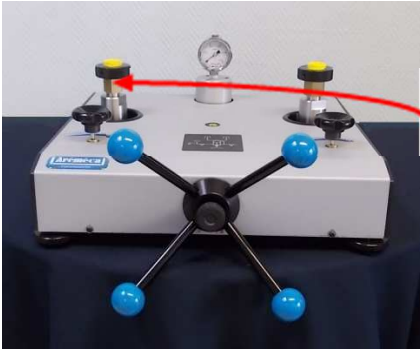
PCU kit + set of weights : upgrade your comparison bench to a DWT

Bench of comparison	Kit DWT (PCU + set of weights)
 <p>CA2-200B</p>	 <p>Kit BA2-1VB (-1 bar) à BA2-200B (200 bar)</p>

✓ **Accessories** (ask us our specific documentation)



Ref OP0057 Accessories suitcase

Ref OP0037 Suitcase with 17 adaptors type M + G + NPT + BSP-TR / Pressure max 1200 bar

Ref OP0062 Cleaning bench

✓ **Transport and packaging**

- **Packaging** : pack is provide for the shipping

Designation/Reference	Dimension / carton or shipping crate	Weight empty / total weight (packaging + device)
packaging	480 x 480 x 340 mm	Total weight ±30 kg



- Note: Shipping is extra. Size may vary if accessories are purchased with the unit.

✓ **Other models available in the range CA2**

(Datasheet is available on request or on our website : www.aremeca-instrumentation.com)

Models	Measuring range		
	Bar or kg/cm ²	PSI	kPa

You'll find other devices and accessories on our website: www.aremeca-instrumentation.com