

$P = F/S$

✓ **Applications**

This primary standard Range are designed to test, adjust and calibrate measuring instruments, mechanical or electronic pressure by comparison (pressure gauges, pressure transmitters or sensors or switches)
The dead weight tester consist of a pressure generator connected to a compressed air source, a piston/cylinder unit, a set of weigh identified. The capstan can adjust the pressure by the gas through the piston. This pressure is balanced by the piston / cylinder which compares the instrument to calibrate the values of pressures generated by the standard.
This reference instrument are used in factory or calibration laboratory. They are robust and easy to use and have a high long-term stability.

✓ **Technical specifications of the range BA2**

- **Calibration :** Our dead weight tester are calibrated under the following conditions of use :
Temperature 20°C - Pressure atmos. 1013.25 hPa - Humidity 50% - acceleration 9.80665 m/s²
In case you don't use it under the conditions mentioned above, it is necessary to recalculate the pressure generated by the dead weight according to the different variables.
- **Source Pressure :** Dry air - gas connection ¼ cylindrical female
- **Check/adjust the seat :** leveling bubble and adjustable feet
- **Connecting for the instrument to be tested :** swivel G1/2 standard – other optional fittings
- **Rotating weigh :** Training masses : manual rotation (motorization in option)
- **Crankcase :** Light alloy aluminium AG3 + high-resistance paint
- **Capstan :** removable for transport
- **Piston/cylinder :** Single piston treated steel or stainless steel + hard chrome depending on the model
- **Répeatability :** 3.10⁻⁵ - **Sensitivity :** 1.10⁻⁵ - **Precision dead weight :** 10⁻⁴
- **Weight :** non magnetic stainless steel – **Total weight** of the set of weights from 4 kg to 48 kg depending on model –Ergonomic shape of the masses, easy loading of the masses on the bell - **Marking** corresponding with the measuring unit choose (bar, mbar, KPa, PSI etc..)
Gravity : standard (9.80665 m/s²) or local gravity without supplement
- **Operating temperature:** 18 to 28°C – 64 to 82°F

✓ **Technical product specifications**

- **Model :** BA2-10B – dead weight single piston
- **Measuring range :** 0.15 to 10 bar / 2.5 to 150 PSI / 15 to 1000 kPa
- **Uncertainty of the pressure measured by the DWT :** 0.0001 + (1.10⁻⁴ x P) (with P in bar)
- **Accuracy :** 0.01% of the scale certificate aremeca (option COFRAC)
- **Weight dead weight without weight :** 22 kg
- **Base generator :** CA2-200B
- **Fluid :** This DWT needs to be connected to a pressure source.
- **Typical cross-section of the piston :** 156.960 mm²
- **Material Piston/Cylinder :** P = stainless steel + hard chrome / C = treated steel
- **Number of piston :** 1

✓ **Various**

- **Device delivered with :** a user manual / an AREMECA calibration certificate traceable to national standards / a technical sheet of the device / 0.5 liter of mineral oil if lubrication system / G1/2 outlet fitting / tools

Note: All our documents are issued in French + English

- **Maintenance :** Our technical service department is at your disposition for the revision, calibration or service your unit – Calibration device recommended every 2 or 5 years depending on your use

✓ **Dimensions of device**

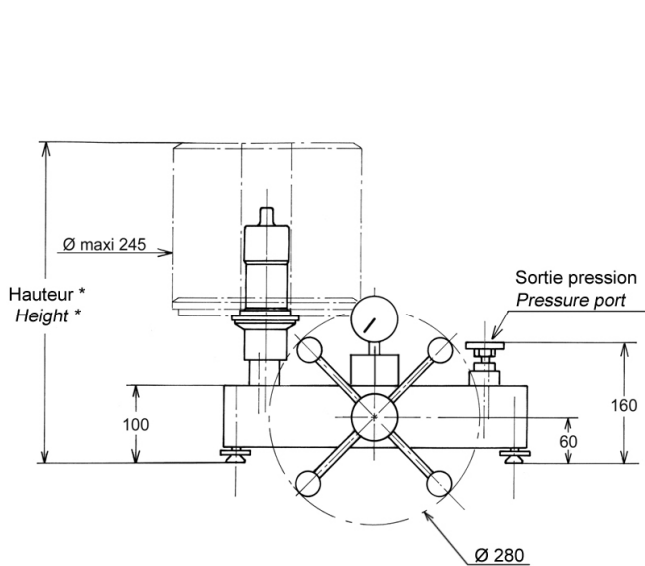

Height with standard set of weight :: (bar, kPa) : 371 mm (PSI) : 330 mm

Unit used : mm

✓ **Standard weight sets and intermediate**

Standard set			
	Pressure (bar)	Total weight	Typical value (g)
Unit : BAR or Kg/cm² (Ref. MB0006)	2	3	3200
	1	2	1600
	0.85	1	1360
	0.5	1	800
	0.2	2	320
	0.1	1	160
	0.05	1	80
	Initial Pressure bell + weight adaptation	0.15	
TOTAL	10.05	11	±16 kg

Intermediate set			
	Pressure (bar)	Total weight	Typical value (g)
BAR (Ref. MB0007)	0.025	1	40
	0.01	2	16
	0.005	1	8
	TOTAL	0.05	4

Standard set			
	Pressure (PSI)	Total weight	Typical value (g)
Unit : PSI (Ref. MB0017)	50	2	5500
	20	2	2200
	10	1	1100
	7.5	1	825
	5	1	550
	2	2	220
	1	1	110
	0.5	1	55
	Initial Pressure bell		
TOTAL	3002.5	11	±19 kg

Intermediate set			
	Pressure (PSI)	Total weight	Typical value (g)
PSI	0.2	2	22
	0.1	1	11
	0.05	1	5.5
	TOTAL	0.55	4

Standard set			
	Pressure (Kpa)	Total weight	Typical value (g)
Unit : kPa	200	3	3200
	100	2	1600
	85	1	1280
	50	1	800
	20	2	320
	10	1	160
	5	1	80
	Initial Pressure bell + weight adaptation	15	
TOTAL	1005	11	±16 kg

Intermediate set			
	Pressure (kPa)	Total weight	Typical value (g)
kPa	2.5	1	40
	1	2	16
	0.5	1	8
	TOTAL	5	4

Other units are available on request

✓ **Options of the dead weight tester**

- **FREE gravitation option** : we will adjust your weight set to the standard or special G (give us the desired value)
- Unit option : several weight set units available (e.g. PSI, BAR, Kg/cm², etc.)
- Option OP0004 : Motorization kit (drive of rotating masses) / Visualization (piston position by indicator lights)
- Option OP0301 : calculator module with dynamic visualization of the position of the piston, automatic display of the pressures generated by the DWT according to the temperature, the atmospheric pressure, with data transfer to a computer for total traceability and calibration certificate edition.
- Option : Set of intermediate weights
- Certificate option : DKD/DAkkS or COFRAC accredited calibration certificate

✓ **Suitcase for shipping**

		<p>Ref OP0101 - Metal box for mass transport Dimensions : 260 x 260 x 310 mm - unloaded weight : 6 kg 7 weights max per box</p>
		<p>Ref OP0301 – carrying case for the masses</p>
		<p>Workstation layout : large: 355 x 505 x 310 mm - empty weight: 13 kg small: 290 x 250 x 310 mm - empty weight: 5 kg 1 or more boxes will be necessary depending on your DWT – Consult us !</p>
		<p>Ref OP0002 - Transport case for the balance or comparison bench. (BH5 or CH3 models contact us !)</p>

✓ **Accessories**



Ref OP0057 Accessories suitcase

Ref OP0025 drain kit for oil

ref OP0037 Suitcase with 17 adaptors type M + G + NPT + BSP-TR / Pressure max 1200 bar

Ref OP0062 Cleaning bench

Ref OP0171 Suitcase adaptors type G / Ref OP0172 Suitcase adaptors type NPT / Ref OP0173 Suitcase adaptors type BSP-TR / Ref OP0174 Suitcase adaptors type M

✓ **Shipping and packaging**

- **Packaging** : woodpack is provided for the shipping

Designation/Reference	Dimension / carton or shipping crate	Weight empty / total weight (packaging + materiel)
Dead weight without weight	470 x 470 x 240 mm	Carton empty 1.5 kg Total weight ±20 kg
Standard weight set	300 x 300 x 170 mm	Carton empty 1.5 kg Total weight ± 18 kg
Wood packaging SB0002	790 x 480 x 340 mm	Suitcase empty 20 kg Total weight ± 58 kg (dead weight + weight set + packaging)



SB0002

- **Note** : shipping is extra.

✓ **Other models available in the range BA2**

(Datasheet is available on request or on our website : www.aremeca-instrumentation.com)

Models single piston

Models	Accuracy	Measuring range		
		Bar or kg/cm ²	PSI	kPa
BA2-200B	10 ⁻⁴	2.5 to 200	25 to 3000	250 to 20000
BA2-120B	10 ⁻⁴	1 to 120	10 to 1600	100 to 12000
BA2-60B	10 ⁻⁴	0.5 to 60	5 to 800	50 to 6000
BA2-1B	10 ⁻⁴	15 mbar to 1 bar		1.5 to 100
BA2-1VB	10 ⁻⁴	-15 mbar to -900 mbar		-1.5 to -90