

Pressure Generator with OIL (Models : CEH)

Pressure Generator with WATER (Models : CEO)



Model: CEH-800B



Model : CEO-700B



Model : CEH-1250B

Concerns the models :

- ✓ model : CEH-800B
- ✓ model : CEH-1250B
- ✓ model : CEO-700B



Zone Industrielle Sud, Rue Marc Séguin - 41100 Vendôme
Tel : +33 (0)2 54 80 79 30 Fax : +33 (0)2 54 80 79 31
E-mail : aremeca@wanadoo.fr - site : www.aremeca-instrumentation.com

Modèle fourni :

N° de Série :

Fabriqué le :

Contact Commercial : d.regal@aremeca.fr

SUMMARY

| | Pages |
|---|-----------|
| 1 - General | 5 |
| 2 - Security | 6 |
| a) Device | 6 |
| b) User | 7 |
| 3 - Put into service | 8 |
| a) Unpacking the unit | 8 |
| b) Installation..... | 8 |
| c) "Put into service" | 9 |
| d) Test run after installing..... | 10 |
| 4 - Procedure | 11 |
| a) Pressure generator models CEH or CEO | 11 |
| 5 - Cleaning/Maintenance | 12 |
| a) Cleaning..... | 12 |
| b) Maintenance | 12 |
| c) Inspection..... | 13 |
| d) Connectors..... | 13 |
| - Threads M10x100, G1/8, 1/8 BSP-TR, 1/8 NPT | 13 |
| - Threads M12x150, M16x150, M18x150, M20x150, G1/4, G3/8, G1/2, 1/4 BSP-TR, 3/8 BSP-TR, 1/2 BSP-TR, 1/4 NPT, 3/8 NPT, 1/2 NPT..... | 13 |
| 6 - Annexes | 14 |
| Options..... | 14 |



Read the instructions before handling and retain this information for future use

All rights reserved AREMECA

The pressure generators models CEH or CEO describes in this manual are designed and manufactured by AREMECA (France).

Our products follow manufacturing procedures and controls in line with our Quality System ISO9001 version 2008 and in accordance with the standards in force.

This manual commissioning informs the user about the functioning of the instrument and the safety limits for work peacefully.

This manual is an integral part of the device. It must be kept close to the workstation and accessible at any time by the user.

AREMECA reserves the right to alter the content or form of this manual at any time and without notice. And to make technical amendments to change the product.

Responsibility AREMECA is not liable for any damage caused by :

- not in accordance with intended usage,
- non compliance with instructions for use,
- use of the instrument by unqualified untrained operator ,
- a transformation / modification of the device carried by the user.

The operator must have read and understand prior to operating mode and use the device to start handling.

For more information



AREMECA - Service Bench Pressure
Zone Industrielle Sud
Rue Marc Seguin
41100 VENDOME

- web site : www.aremeca-instrumentation.com
- Contact : E-mail : aremeca@wanadoo.fr / Phone : +33 (0)2 54 80 79 30 / Fax : +33 (0)2 54 80 79 31

to Contact Sales Manager : d.regal@aremeca.fr

a) Device

Device identification



indicates the model of comparator
ex : CEH-1250B

indicates the serial number of comparator

indicates the date of commissioning of the unit

Intended use of the device

Before switching on the device, ensure that the technical characteristics (measuring range, precision, fluid etc...) correspond to your needs



> For example : the maximum pressure defined for this compressor must not be exceeded

The pressure comparator is designed and manufactured for use as described in this document

In this case of misuse or mishandling, outside the technical specifications contained in this manual. The instrument must be immediately isolated, identified as inoperative and must be checked by our service department.

Precautions storage and transport

It's necessary to take care of the unit during storage or transportation. It must be protected from moisture, shock, extreme temperatures and shouldn't be removed or changed.



*> On our catalog, we have a suitcase, adapted to transport your device.
(Ref.OP0002)*

If the comparator is moved to a new environment (warmer, colder, etc..). Observe the phase of "quarantine" and wait until the device temperature stabilizes at room temperature before handling.

b) User

User qualifications



> Improper use of the device can cause significant bodily injury and property damage.

Qualified operator, due to : its product training, knowledge in the field of metrology and experiences in field of pressure and knowledge on standards and guidelines, is able to perform the operations describes in this manual. He will be able to detect potential dangers.

AREMECA offers on demand, an installations / commissioning of the instrument performance.

Personal protective equipment (PPE)

The personal protective equipment must be defined in the security register of the user company and made available to the operator. These devices are used to protect the operator from potential risks that impede their safety and health at work.

- Protecting fluid



> Wear eye protection : protects the eyes against splashes and projections of the fluid.



> wear gloves : protect the skin against irritation, allergies.

AREMECA provides for oil dead weight, a bottle of colorless mineral oil. Safety data sheet of used oils are available on request.

a) Unpacking the unit

Upon receipt of the equipment, check the status and content of your package. All of the following elements must be present in the package :

- 1 compressor
- 0.5 liter of Oil for models CH1, CH2
- 1 capstan consists of 4 delivered arms removed
- 2 connectors G1/2 (supplied as standard unless otherwise specified)
- 1 manual

Check that there isn't damage or breakages during transport. If there are missing items, please immediately notify AREMECA or your local distributor for what is missing.

b) Installation

Preferably, install your unit in a stable and controlled environment



You will get better performance if :
> the temperature and humidity of the room are stable,
> the workstation is clean and dry, protected from drafts, noise, vibration, and without passing

Component Identification

- 1 : capstan
- 2 : axis de rotation
- 3 : clamping knob
- 4 : connector
- 5 : fastening screw
- 6 : tank
- 7 : valve

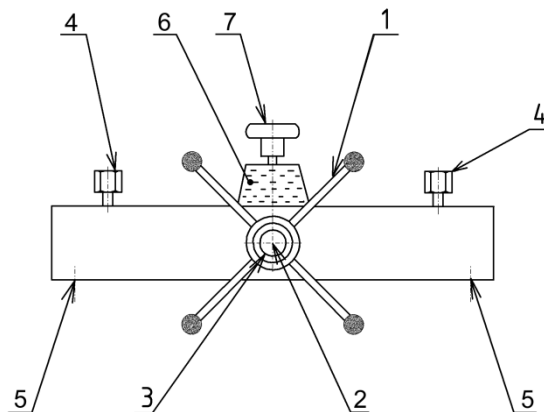

Installation / Fixation / Assembly

- Install pressure generator on a established stable an rigid about 0,90 m tall.
- Insert the capstan 1 on the axis of rotation 2, screw the clamping knob 3 at the axis of rotation
- Fix the generator on the table with the 4 fastening screw 5 use the supplied key. See plan of drilling (following page)

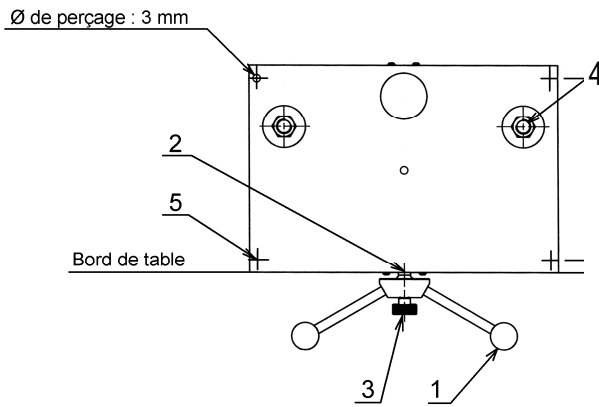

Noted : This operation is not imperative if the generator is used for pressures lower than 400 bar ; in this case, insert 4 skates of stabilization supplied in 4 openings Ø 9 mm on the crankcase.

- Make sure that o-ring are well positioned on the connectors 4.



> Dirty or polluted gauges must be cleaned before mounting the pressure generator to prevent contamination on the hydraulic circuit. Don't clean the tank with alcohol
Option : cleaning bench (Ref.OP0062)

c) Put into service



> the generators are equipped with precision valves instrumentation, it is imperative to observe the following guidelines to keep your machine in good working condition.

Filling the device with the fluid

1. Open valves 7 and turn the capstan 1 in the direction of clockwise until reaching the stop limit switch forward.
2. Remove the filler cap on the tank
3. Fill the 3/4 tank with the correct fluid. Don't use other liquids.



> Our devices are mounted and designed to a standard use. They function with the fluid provided. Some fluids such skydrol, castor oil etc... are corrosive and can damage the o-ring of your device.

On request : we can deliver a device designed for these fluids.

4. Put the device to be tested and the reference instrument on the connectors 4.

5. Turn completely the capstan in the opposite direction of clockwise until the stop end (the variable volume of the generator is loaded with the fluid).

6. If you need, complete the level of the tank.

Purging the device

1. Close the valve 7. Tighten without excess.

2. Unscrew the devices to be tested of the connectors **4**.
3. Turn the capstan **1** in the direction of clockwise until the fluid is at the outputs
4. Screw the devices on connectors ; wipe off the excess fluid.
5. Open the valve **7**.
6. Turn the capstan **1** in the direction of clockwise until the end stop (the residual air is now driven).
7. Turn the capstan **1** in the opposite direction clockwise until the stop end position

The pressure generator is ready to use

d) Test run after installing

1. Perform a calibration test instrument with a "test" known correct (see chapter procedure) to verify and validate the operational statuses of the pressure generator

Noted : During calibration of instruments with a large volume, the amount of fluid in the pressure generator may not be sufficient to achieve the desired pressure. in this case the instrument must be filled as much as possible before being connected to the generator to reduce the useful volume of fluid.



> As an alternative, we provide you with a hand pump Ref. OP0158 with a reservoir volume of 327 cm³

2. Lower the pressure by turning the capstan in the opposite direction of the clock hand and remove the instrument "test". If necessary use the key to start unscrewing the rotating connector
3. **The device is now ready to use.**

> Hydraulic diagram

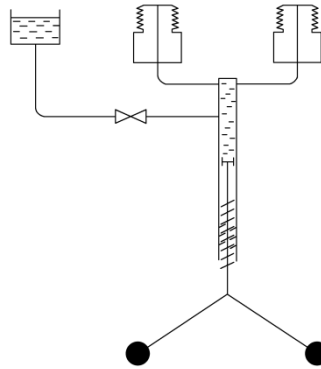

> **Pressure mounted**



> *Observe the maximum operating pressures of the pressure generator*

Maximum operating pressure : CEH-800B → 820 bar and CEH-1250B → 1270 bar
CEO-700B → 720 bar

- a) Connect the instrument on the connector **4** (make sure that o-ring are well positioned).
- b) Check the valve is open and the capstan is in end position stop (turn in the opposite direction of clockwise).
- c) Close the valve **7**.
- d) Turn the capstan **1** in the direction of clockwise until reaching the calibration pressure.
Maximum operating pressure :
 - CEH-800B (oil) → 820 bar
 - CEH-1250B (oil) → 1270 bar
 - CEO-700B (water) → 720 bar
- e) **Realize the measurement point.**

> **Reduce pressure**

- f) After the readings measures, turn the capstan **1** in the opposite direction clockwise
- g) Open the valve **7**.
- h) **The instruments can be disassembled.**

Chap.5 - Cleaning/Maintenance

a) Cleaning

The generator cleaning and checking fluid levels are the only periodic maintenance required. No additional maintenance should be necessary if all instructions are followed.

We recommend a complete overhaul of the unite every 2 years. This operation can only be performed by the manufacturer. If necessary, send us your device for maintenance. A complete assessment of your device will be made and an estimate of rehabilitation will be sent.

Instructions reminders :

- Use only oil H32 for models CEH or water for models CEO. The guarantees of performance and operation are insured with the use of these oils.



> wear are protection : protects the eyes against splashes and projections of the fluid.

- Don't remove the protective cover.

NOTES : For comparators without isolation valves **A'**, the capacity of the pumps 60 cm³ may be insufficient to fully complete a high volume measuring device. In this case, a solution with intermediate valve is possible by interposing it between the bench and the device. We repeat the cycle as many times as necessary. For these applications, a specific kit can be supplied.

It can also fill in advance before mounting the pressure generator.

b) Maintenance

> Valves

Generator and dead weight are equipped with instrumentation valves, it's imperative to observe the following guidelines :

- Maximum torque applicable abutment valve closed = 4 Nm.

> Tank oil

Make sure the tank contains enough liquid to make the required calibrations. If necessary, fill the tank with the same liquid as that already used. Don't mix different types or brands of fluids into the generator and use the recommended oil.

Skydrol, solvents may damage the o-rings mounted on a generator.

Keep clean bench, wipe traces of fluid, and particularly the oil condition in the tank to detect traces of pollution. If the fluid in the system is dirty, drain the device and remove dirty oil.



> Option : cleaning kit Ref. OP0025 you will aspirate oil dirty present in the tank.

Don't clean the tank with alcohol

c) Inspection

It's recommend to a service of your device every 2 years. The average response time is 2 weeks. Cleaning generator, replacement o-rings, testing pressure rise and stability are made.

d) Connection

The device is equipped with a specific connector for less than 1250 bar pressure. It is necessary to orient the ring according to the type of connector correctly.

Thread M10x100, G1/8, 1/8 BSP-TR, 1/8 NPT

For these connectors guide ring, mark : **000** visible.
The connector must be tightened by hand.

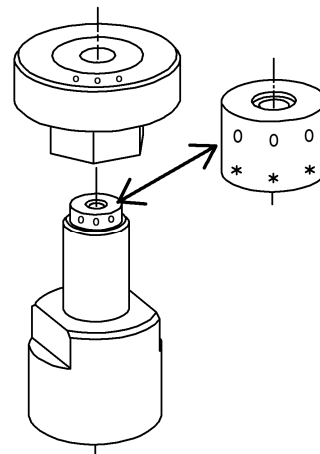

Thread M12x150, M16x150, M18x150, M20x150, G1/4, G3/8, G1/2, 1/4 BSP-TR, 3/8 BSP-TR, 1/2 BSP-TR, 1/4 NPT, 3/8 NPT, 1/2 NPT

For these connectors guide ring, mark : ******* visible.
The connector must be tightened by hand.

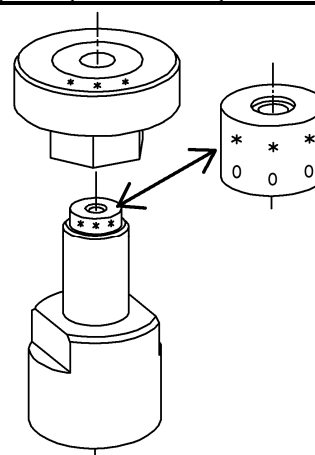

> Available as an option :

Suitcase with 4 connectors type G (Ref.OP0171)

Suitcase with 4 connectors type NPT (Ref.OP0172)

Suitcase with 4 connectors type BSPTR (Ref.OP0173)

Suitcase with 5 connectors type M (Ref.OP0174)

Suitcase with 17 connectors (Ref.OP0037)

standard o-ring (Ref.OP0038CEO)



Chap.6 - Annexes

> OPTIONS

Oils

OP0032 : 1 liter Oil H32

(CEH-800B + CEH-1250B)

Connectors

OP0174 : Suitcase with 5 connectors metrics - M10x100 ; M12x150 ; M16x150 ; M18x150 ; M20x150

OP0171 : Suitcase with 4 connectors gas cylindrics - G1/8 ; G1/4 ; G3/8 ; G1/2

OP0172 : Suitcase with 4 connectors NPT - 1/8NPT ; 1/4NPT ; 3/8NPT ; 1/2NPT

OP0173 : Suitcase with 4 connectors BSPTR - 1/8BSPTR ; 1/4BSPTR ; 3/8BSPTR ; 1/2BSPTR
OP0037 : Suitcase with 17 connectors - all connectors

Kit cleaning

OP0025 : Cleaning kit for tank
OP0062 : Cleaning bench for manometers
OP0023 : Separator

Transport

OP0029 : Protective cover for economic generator



